

NOTE:

1. MATERIAL:
 - 1.1 INSULATOR:HIGH TEMPERATURE PLASTIC UL94V-0;SEE NOTES
 - 1.2 CONTACT:C5210-EH(T=0.20mm)
 - 1.3 SHELL:SUS201(T=0.30mm)
 - 1.4 COVER:SUS201(T=0.20mm)
2. ELECTRICAL CHARACTERISTICS:
 - 2.1 CONTACT RESISTANCE:30mΩ Max
 - 2.2 CONTACT CURRENT RATING:1.5A
 - 2.3 DIELECTRIC WITHSTANDING VOLTAGE:500V R. M. S.
 - 2.4 INSULATION RESISTANCE:100 MEGA OHMS Min
 - 2.5 OPERATING TEMPERATURE:-40° C ~ 85° C
3. MECHANICAL CHARACTERISTICS:
 - 3.1 INSERTION FORCE: 3.50 Kgf MAX;
 - 3.2 WITHDRAWAL FORCE:1.02Kgf MIN (INITIAL);
0.8Kgf MIN(AFTER TEST)
 - 3.3 DURABILITY:5,000 CYCLES
4. PLATING
 - 4.1 TERMINAL CONTACT: 1u" GOLD PLATING ALL OVER
50u" MIN NICKEL AND 80u"MIN MATTE Tin ALL OVER
50u" MIN NICKEL ON SOLDER AREA
 - 4.2 SHELL:50u"MIN. BLACK NICKEL ALL OVER
 - 4.3 COVER:NO-PLATED
5. PART NUMBER:

H181-32XAS-23A

1: G/F	1: Tray
2: 5u"	2: Tape reel
3: 10u"	
4: 15u"	
5: 30u"	

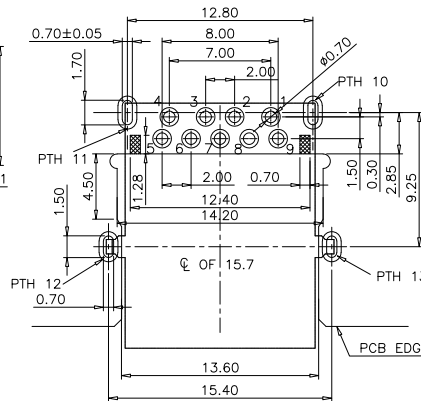
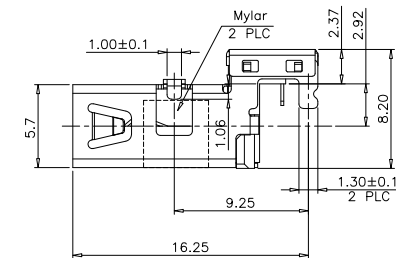
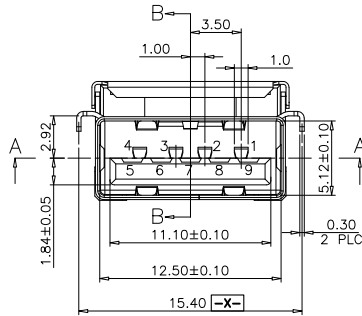

TOLERANCE: ±0.05, THICKNESS: 1.2mm
RECOMMENDED PCB LAYOUT
(TOP VIEW)
KEEP OUT AREA

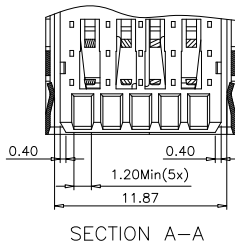
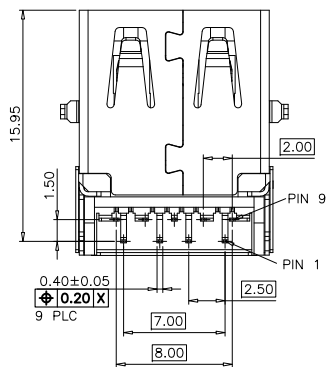

HULYN

深圳惠興力電子有限公司
SHEN ZHEN HUILY ELECTRONICS CO.,LTD.

A0	RELEASED	Peng	02/08-17
REV	DESCRIPTION.	APPD.	Date

FILE NO : H181(Series)	TITLE 圖名	USB 3.0 CH=-2.92mm, REC, RVS, DIP TYPE		UNIT 單位	mm inch
TOLERANCE(公差): 0.000 mm ± 0.075 mm 0.00 mm ± 0.15 mm 0.0 mm ± 0.25 mm	PART NO. 料號	H181-32XAS-23A		SCALE 比例	1:1
	DRAWN BY 製圖	Peng	DATE 日期	2017-08-02	REV. 版本
	CHECKED BY 審核	Zhu	DATE 日期	2017-08-02	A.0

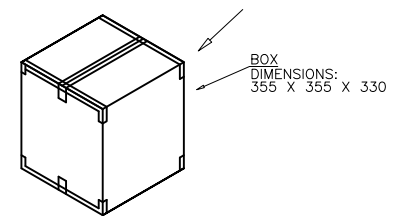
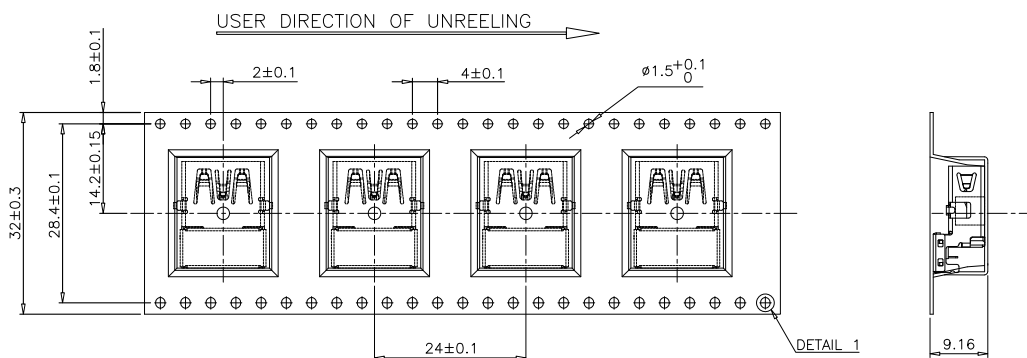
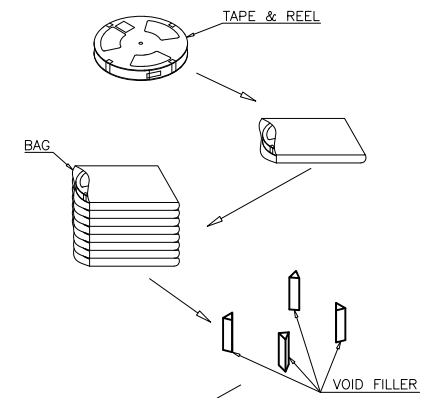
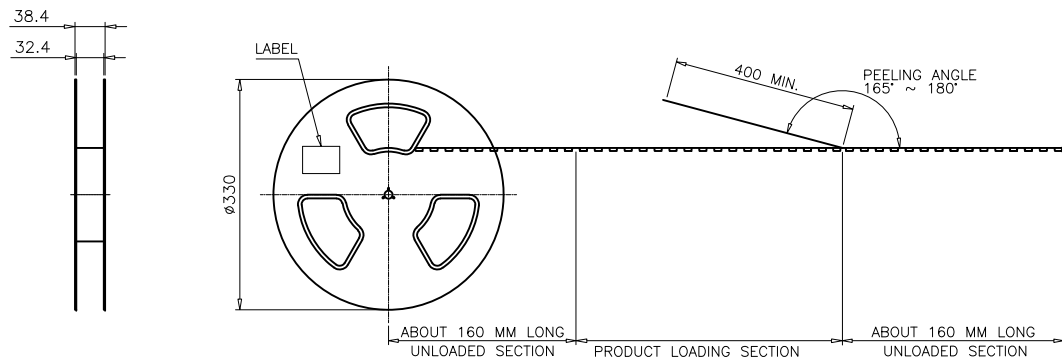

- NOTE:**
- MATERIAL:**
 BOX: FIBREBOARD, CORRUGATED, DOUBLE WALL.
 TAPE: POLYSTYRENES, HEAT-RESISTANT TEMPERATURE: 120° C, BLACK COLOR.
 REEL: POLYSTYRENES, HEAT-RESISTANT TEMPERATURE: 70° C, BLUE COLOR.
 BAG: POLYETHYLENE, HEAT-RESISTANT TEMPERATURE: 100° C.
 - PEELING STRENGTH: 0.1 ~ 1.3 N (10 ~ 130 GRAMS)
 - PEELING SPEED: 300 mm/min.
 - EACH BAG SHALL BE INCLUDED DESICCANT.

300	8	2400 PCS	-- KG	-- KG
REEL	REELS/CARTON	QUANTITY	GROSS WEIGHT	NET WEIGHT

HULYN 深圳惠興力電子有限公司 SHEN ZHEN HUILY ELECTRONICS CO.,LTD.

A0	RELEASED	Peng	02/08-17
REV	DESCRIPTION.	APPD.	Date

FILE NO : H181(Series)	TITLE 圖名	USB 3.0 CH=-2.92mm, REC, RVS, DIP TYPE		UNIT 單位	mm inch
TOLERANCE(公差): 0.000 mm ± 0.075 mm 0.00 mm ± 0.15 mm 0.0 mm ± 0.25 mm	PART NO. 料號	H181-32XAS-23A		SCALE 比例	1:1
	DRAWN BY 製圖	Peng	DATE 日期	2017-08-02	REV. 版本
	CHECKED BY 審核	Zhu	DATE 日期	2017-08-02	